



Chester-Jensen Co., Inc.

# air agitated **ICE BUILDERS**



Provide low-cost  
32° cooling water  
by “storing”  
refrigeration



**Catalog Section M**



Chester-Jensen Co., Inc.

# air agitated ICE BUILDERS

The ice builder method of “storing” refrigeration in the form of an ice bank which may be built up during off-peak or non-operating hours has proven itself to be one of the most efficient and economical methods of providing cooling water at 32°F. Among the economies of this system are:

1. Less of an investment in refrigeration equipment, since it can be sized to average demand rather than peak demand.
2. An appreciable reduction in power cost.
3. Automatic operation; attention ordinarily required to balance refrigeration supply to demand is unnecessary.
4. Operation of refrigeration equipment at the highest efficiency, at all times.

## Air Agitation

To these basic economies of ice builder operation, Chester-Jensen adds greater efficiency with improved economy developed from our

own concept of the principle of air agitation. This consists of an installed single sinuous stainless steel tube at the bottom of the ice builder that is perforated to allow air under pump pressure to be distributed throughout the water in the unit.

The result of this method of air agitation appears in the illustration on page 6, showing air bubbles bursting through the water at the top of the ice builder.

This turbulent action causes an even melting of the ice bank and a constant low temperature of the outgoing water as long as there is any ice on the coils. The usual practice is to have the air blower and ice water pump wired together so that as the ice water is being circulated, it is also being air agitated. Optionally, using air agitation during the freezing period will result in formation of a more dense ice.

Air required for agitation is supplied with a low pressure air blower. The cost of air agitation is insignificant compared with other types of agitation.

## Construction

Chester-Jensen Air Agitated Ice Builders are ruggedly constructed with liners of heavy steel plate at the sides; ends and bottom are supported by heavy-gauge angles and channels. The sectional outer jacket is of stucco finish aluminum, broken for greatest rigidity. Section joints are stripped with stainless steel. Single-thickness, 16-gauge painted or stainless steel sectional covers are interlocking and of small size to enable easy handling. Model M covers are pitched from center bridge. Model ML covers are flat.

Chester-Jensen Air Agitated Ice Builders have standard capacities from 1,000 to 142,000 lbs. Units are available in differing dimensions for the same capacity and may be custom built to fit available space. Replacement units can be supplied to accommodate any refrigeration tonnage requirement.

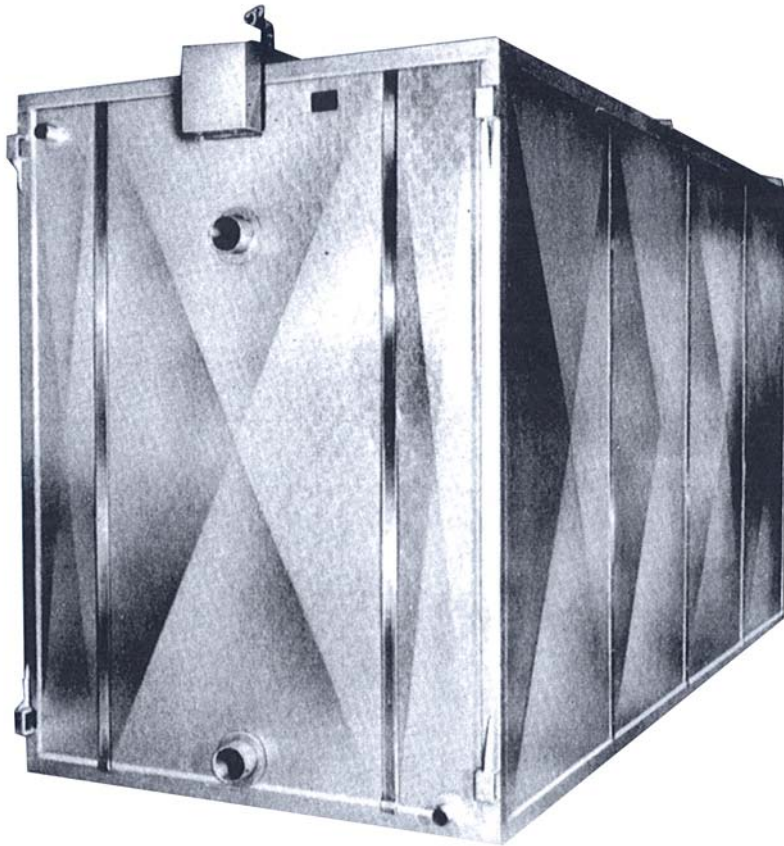

The Chester-Jensen Air Agitated Ice Builder shown to the left is of 40,000 lbs. ice capacity and has sectional, interlocking covers which facilitate the inspection of the interior. Standard covers are un-insulated but may have 2" insulation at an added cost. Units are completely adapted to outdoor installation.

The illustration to the right shows an Ice Builder assembled as a package unit, including Chester-Jensen Plate Heat Exchanger, which is optional equipment and may be mounted separately or omitted entirely. Other equipment regularly furnished with the Ice Builder may also be remotely mounted if desired.

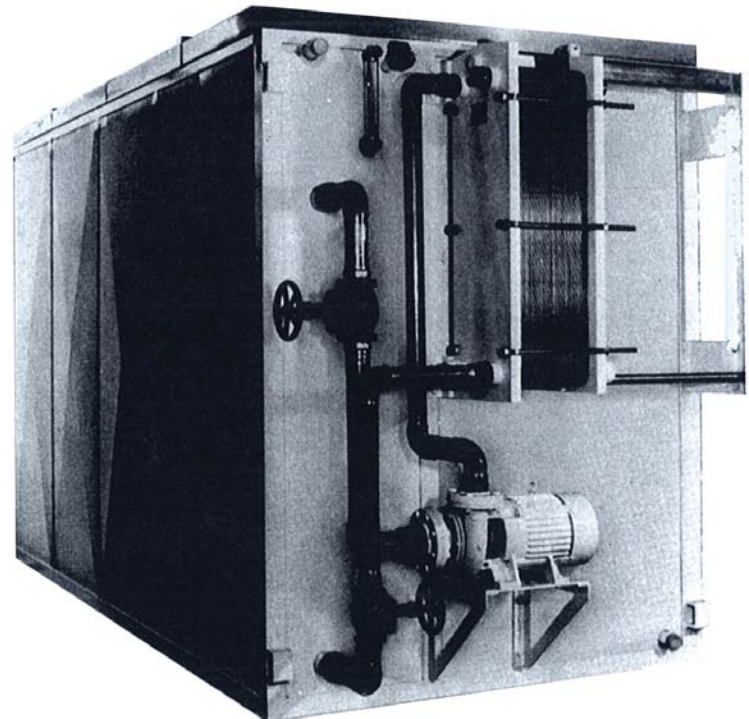

The C-J Air Agitation principle of applying air with a low pressure blower through a single sinuous 1-1/2" stainless steel pipe, capped at one end, allows the entire air line to be blown clear of any sediment which could accumulate. This process is easily accomplished by removing the cap on one end of the stainless steel pipe which extends above water line at the opposite end of air inlet.



# Ice Builder Specifications

MODEL	ICE CAP. LBS.	"A" TANK WIDTH	"B" TANK HEIGHT	"C" TANK LENGTH	"D" SW. WATER CONN.	WATER CAP. GAL.	AIR AGITATOR H.P.	FLOODED CHG NH <sup>3</sup> LBS.	DIRECT EXP CHG NH <sup>3</sup> LBS. (APPROX.)	DIRECT EXP CHG FREON LBS. (APPROX.)	SHIPPING WEIGHT LBS.	OPERATING WEIGHT LBS.	NON COMP CAP. TONS
ML-2-6-1	1,000	2'-0"	4'-4"	8'-6"	2"	350	1		12	17	1,900	5,000	1
ML-4-6-2	2,000	3'-2"	4'-4"	8'-6"	2"	600	1	54	24	34	2,400	9,300	2
ML-6-6-3	3,000	4'-4"	4'-4"	8'-6"	2"	900	1	82	36	51	2,700	11,000	3
ML-6-8-4	4,000	4'-4"	5'-4"	8'-6"	2"	1,100	1	108	48	68	3,250	13,000	4
ML-8-8-5.5	5,500	5'-6"	5'-4"	8'-6"	2"	1,500	1	149	66	93	3,750	17,200	5
ML-6-8-6.5	6,500	4'-4"	5'-4"	12'-6"	3"	1,700	1	175	78	110	4,350	19,100	6
ML-6-10-8	8,000	4'-4"	6'-4"	12'-6"	3"	2,000	1	216	96	136	4,600	22,300	8
ML-8-10-10	10,000	5'-6"	6'-4"	12'-6"	3"	2,600	1	270	120	170	5,400	28,400	10
ML-8-12-12	12,000	5'-6"	7'-4"	12'-6"	3"	3,050	1	325	144	204	6,700	33,200	12
M-6-12-12	12,000	4'-5"	8'-5"	15'-1"	4"	2,900	1	324	144	204	9,700	32,800	12
M-6-12-14	14,000	4'-5"	8'-5"	17'-3"	4"	3,200	1	378	168	238	10,150	37,000	14
M-6-12-16	16,000	4'-5"	8'-5"	19'-1"	4"	3,500	1	432	212	272	10,650	41,200	16
M-8-10-11	11,000	5'-7"	7'-3"	12'-7"	4"	2,810	1	297	132	187	8,200	31,700	11
M-8-10-15	15,000	5'-7"	7'-3"	16'-7"	4"	3,700	1	405	180	255	10,850	41,060	15
M-8-10-18	18,000	5'-7"	7'-3"	19'-7"	3"	4,475	1	486	216	306	12,250	48,000	18
M-8-12-15	15,000	5'-7"	8'-5"	14'-1"	4"	3,525	1	405	180	255	10,100	38,700	15
M-8-12-20	20,000	5'-7"	8'-5"	18'-7"	4"	4,760	1	540	240	340	13,800	52,600	20
M-8-12-25	25,000	5'-7"	8'-5"	22'-7"	5"	5,995	1	675	300	400	15,650	66,500	25
M-10-10-15	15,000	6'-9"	7'-3"	14'-0"	4"	3,825	1	405	180	255	10,300	40,350	15
M-10-10-20	20,000	6'-9"	7'-3"	18'-4"	4"	4,900	1	538	240	340	12,750	50,600	20
M-10-10-25	25,000	6'-9"	7'-3"	22'-2"	5"	6,000	1	665	280	400	15,850	62,000	25
M-10-12-20	20,000	6'-9"	8'-5"	15'-1"	4"	4,560	1	540	240	340	11,700	51,000	20
M-10-12-25	25,000	6'-9"	8'-5"	18'-3"	5"	5,650	1	675	290	400	15,600	60,800	25
M-10-12-30	30,000	6'-9"	8'-5"	21'-10"	5"	6,740	1	810	348	480	17,800	72,700	30
M-10-12-35	35,000	6'-9"	8'-5"	24'-6"	5"	7,640	1½	935	400	560	19,300	82,300	35
M-10-14-25	25,000	6'-9"	9'-7"	16'-1"	5"	5,830	1	675	290	400	14,300	63,300	25
M-10-14-30	30,000	6'-9"	9'-7"	18'-10"	5"	6,700	1	810	348	480	16,250	72,200	30
M-10-14-35	35,000	6'-9"	9'-7"	21'-7"	5"	7,750	1½	945	400	560	18,400	82,200	35
M-10-14-40	40,000	6'-9"	9'-7"	24'-7"	5"	8,720	1½	1,080	460	640	21,550	92,800	40
M-12-12-30	30,000	7'-11"	8'-5"	18'-7"	5"	6,990	1	810	348	480	16,300	74,700	30
M-12-12-35	35,000	7'-11"	8'-5"	20'-7"	5"	7,760	1½	945	400	560	18,250	82,900	35
M-12-12-40	40,000	7'-11"	8'-5"	23'-7"	5"	8,930	1½	1,080	460	640	20,650	94,300	40
M-12-12-45	45,000	7'-11"	8'-5"	26'-7"	5"	10,120	1½	1,215	520	720	23,250	106,500	45
M-12-12-50	50,000	7'-11"	8'-5"	29'-1"	6"	11,160	1½	1,350	580	800	25,150	115,500	50
M-12-14-45	45,000	7'-11"	9'-7"	22'-7"	6"	9,890	1½	1,215	520	720	23,550	105,000	45
M-12-14-50	50,000	7'-11"	9'-7"	25'-4"	6"	10,990	1½	1,350	580	800	25,250	114,500	50
M-12-14-55	55,000	7'-11"	9'-7"	27'-7"	6"	12,120	3	1,485	640	880	26,800	125,650	55
M-12-14-60	60,000	7'-11"	9'-7"	29'-7"	6"	13,030	3	1,620	700	960	27,400	134,000	60
M-12-14-65	65,000	7'-11"	9'-7"	32'-1"	6"	14,300	3	1,755			32,100	149,700	65
M-14-14-70	70,000	9'-1"	9'-7"	29'-7"	6"	15,110	3	1,890			33,800	170,250	70
M-14-14-80	80,000	9'-1"	9'-7"	33'-7"	6"	16,940	3	2,150			36,250	192,500	80
M-14-14-90	90,000	9'-1"	9'-7"	37'-7"	6"	18,880	3	2,440			42,850	215,750	90
M-14-14-100	100,000	9'-1"	9'-7"	41'-7"	6"	20,820	5	2,700			45,100	237,000	100
M-17-14-120	120,000	10'-10"	9'-7"	41'-7"	6"	25,000	5	3,240			54,000	266,000	120
M-20-14-142	142,000	12'-7"	9'-7"	41'-7"	6"	29,500	5	3,834			58,700	313,000	142

PLEASE CONTACT CHESTER-JENSEN FOR D/X CHARGES ON UNITS OVER 60,000 LB. ICE CAP.

**STANDARD RATING DATA**

1. All ice builders are nominally rated at 1000 pounds of ice per ton of refrigeration. This means the normal freezing or evaporation rate is 12,000 BTU per hour for 12 hours time to build each 1000 pounds of ice. Ice builder capacity is based on a 2-1/2" ice thickness.

- 2. The maximum evaporation rate with a bare coil and air agitation is approximately 150%\* of the nominal rating.
- 3. The maximum ice melting rate is approximately 75% full normal ice capacity in one hour. To calculate ice requirement, divide the total BTU cooling load day by 144 to determine pounds of ice needed per day.

**EXAMPLE:** One Day's Operation

TOTAL DAILY LOAD =  
100,000 lbs. of product

SPECIFIC HEAT = .9

COOLING RANGE = 100°F - 60°F

FORMULA:

$$\frac{100,000 \times .9 \times 40^\circ}{144} = 25,000 \text{ lbs. of ice required}$$

Note: Add to the above as desired for future load increases due to possible business expansion and select a unit from the table on page 3.

\*For Full Flooded Ammonia

**Dimension Drawings**

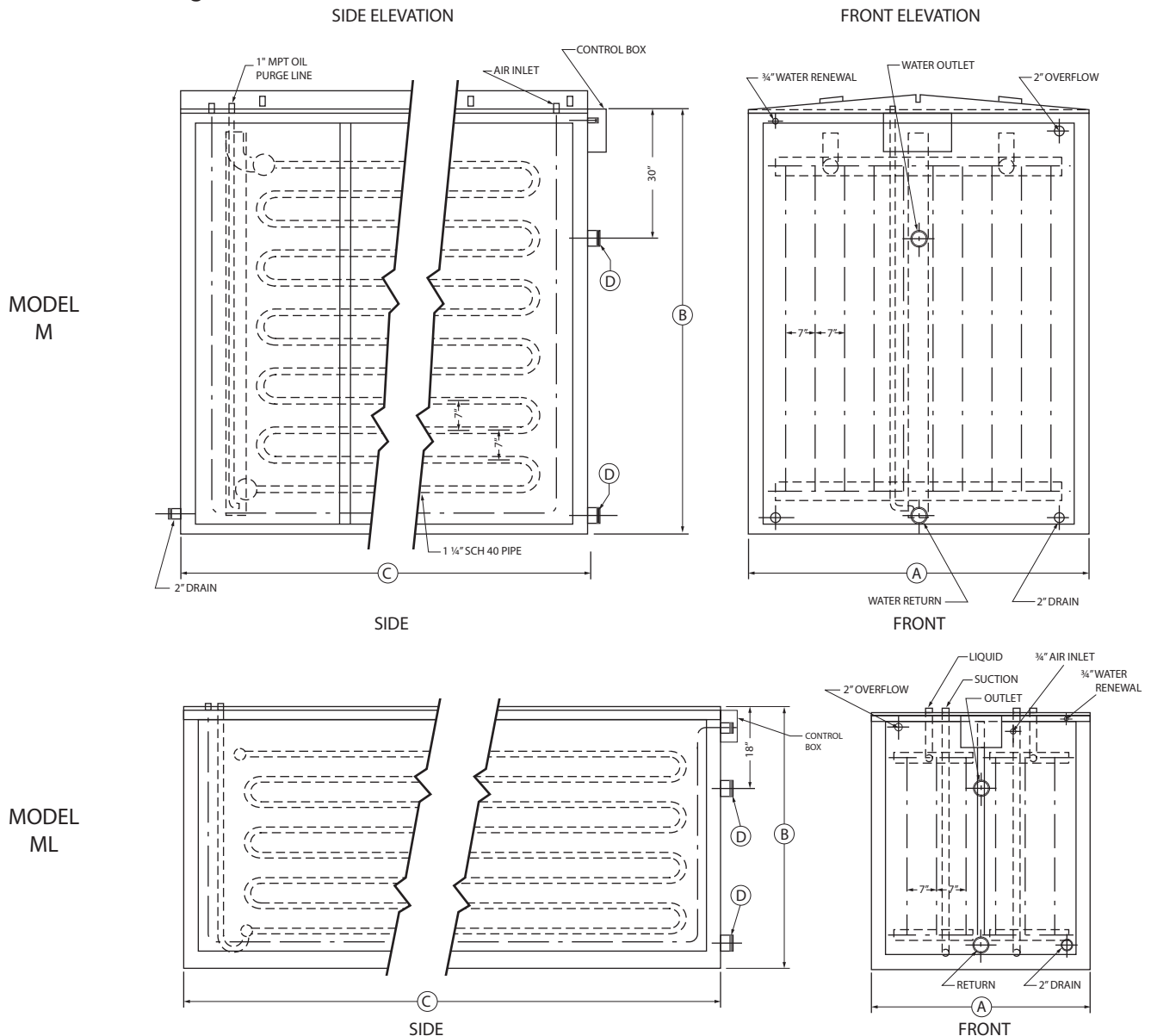

# Specifications (continued)

## TANK LINER

Heavy steel plate, sides ends and bottom; reinforced with heavy steel angle channel.

## OUTER JACKET

Stucco finish aluminum sectional jacket, overlap/dovetail construction at top, bottom and corner rails. Section joints are stripped with stainless steel. Heavy steel angle top, bottom and corner rails are primed and painted.

## COVERS

16-gauge steel sectional. Single thickness, interlocking sections. Model M covers pitched from center bridge. Model ML covers are flat. Primed and painted. (Covers with 2" insulation at extra cost.)

## INSULATION

3" fibre glass sides and ends; 2" styrofoam bottom.

## WATER CONNECTIONS

Chilled water outlet and return (see "D" in the table on page 3). Threaded thru 3" IPS. Larger sizes are plain end (for welding). 2" drain each end; 2" overflow. 3/4" makeup.

## COILS

1-1/4" standard schedule 40 steel pipe on Model M. 1" schedule 40 on Model ML. Welded liquid and suction headers. Direct expansion units larger than 60,000 pounds or for liquid refrigerant recirculation are furnished with a split coil arrangement. Direct expansion units for multi-compressor operation are available with split liquid and suction headers, requiring extra ice thickness controls. Check with the factory for details and pricing. Freon coils are evacuated to 500 microns or less and sealed with a neutral charge of dry nitrogen.

## AIR DISTRIBUTOR

1-1/2" stainless steel tubing; single sinuous, perforated with one end capped; inlet end equipped with check valve.

## AIR PUMP

Pump with V-belt drive and motor on common base. 3/60/220 volt. (For remote mounting)

## ICE THICKNESS CONTROLS

Automatic ice thickness control mounted, 120 volt.

## FLOODED AMMONIA CONTROL

ASME certified surge drum with liquid and suction legs. Electric float switch liquid level control, liquid solenoid valve with strainer, hand valve, hand expansion valve, hand expansion bypass, interconnecting fittings and nipples and relief valve.

## DIRECT EXPANSION CONTROL

Ammonia or Freon—Remote bulb thermal expansion valve or valves with adapters for connection to liquid headers are furnished as required.

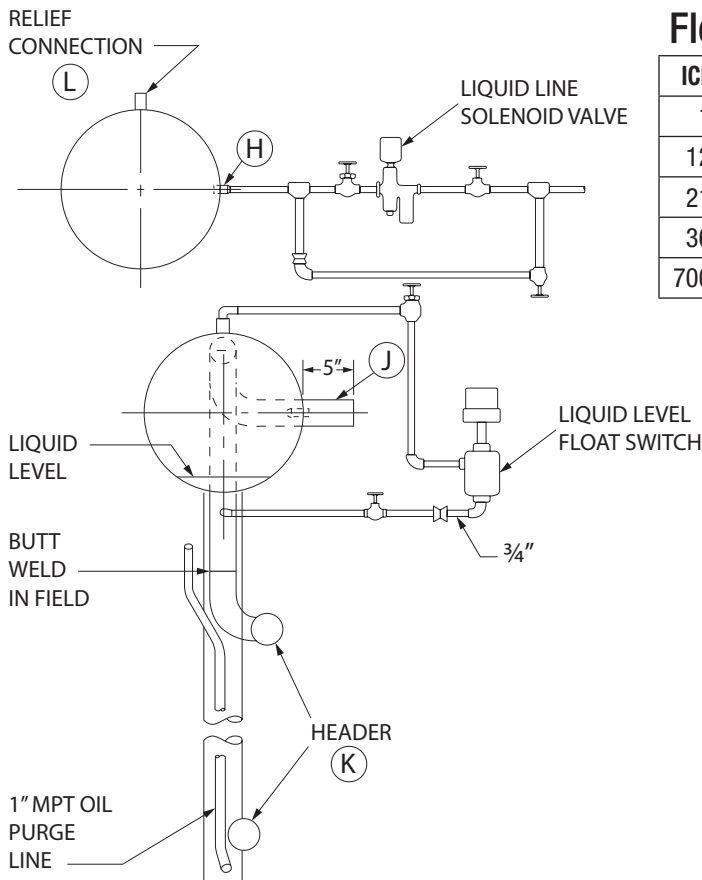

## Flooded Ammonia Control

ICE CAPACITY	"A"	"B"	"C"	"D"	"F"	"G"	"H"	"J"	"K"	"L"
1000-10000	*	*	*	*	*	*	*	*	*	*
12000-20000	16"	60"	28"	14"	2"	3"	1/2"	2"	3"	1/2"
21000-35000	20"	60"	28"	14"	2 1/2"	3"	3/4"	2 1/2"	3"	3/4"
36000-69000	24"	84"	42"	21"	3"	4"	1"	3"	4"	3/4"
70000-100000	24"	108"	56"	28"	4"	5"	1"	4"	5"	3/4"

\* On Application

- Ⓒ LIQUID IN TO ICE BUILDER
- Ⓓ LIQUID FEED
- Ⓔ SUCTION RISER

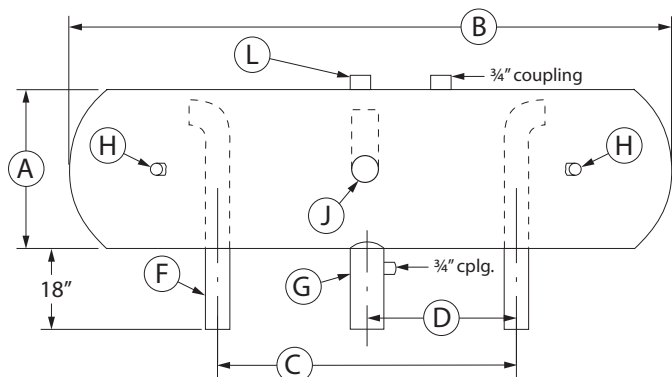



### OPTIONAL EQUIPMENT

- Insulated Covers—Double thickness 16-ga. steel with 2” fibre glass insulation, primed and painted. Also available in stainless steel.
- Schedule 80 Steel Pipe Coils
- Stainless Steel Coil Assembly
- Stainless Steel Tank Liner
- Water Level Control—including 3/4” water solenoid valve, 120 volt.

- Ice Thickness Control—Additional mounted ice thickness control, 120 volt. (For multi-compressor installation)
- Suction Pressure Control—Dual pressure regulator with strainer 120 volt.
- Ladder—Steel, welded, and removable, to be located where specified. Primed and painted.
- Peep Hole—7” peep hole opening with lift off single thickness cover.

Illustration, shown to the left, shows air bubbles surfacing through water at the top of a large air agitated ice builder. Ice coated coils are visible below.

The photograph clearly shows that air, and consequently water, follows no pre-charted course through the coils, as is the case when water flow is directed by baffles or mechanical agitation. Instead, the whole body of water is uniformly agitated and each individual length of pipe carries over its entire surface its full share of the load.

By this means, ice not only forms more evenly on the coils but melts more evenly from them. Only when the latter and more complex problem is solved can the ice builder deliver full capacity with water at uniformly low temperature from start to end of run.

The Chester-Jensen Air Agitated Ice Builder solves this problem in the simplest, most efficient manner yet devised.

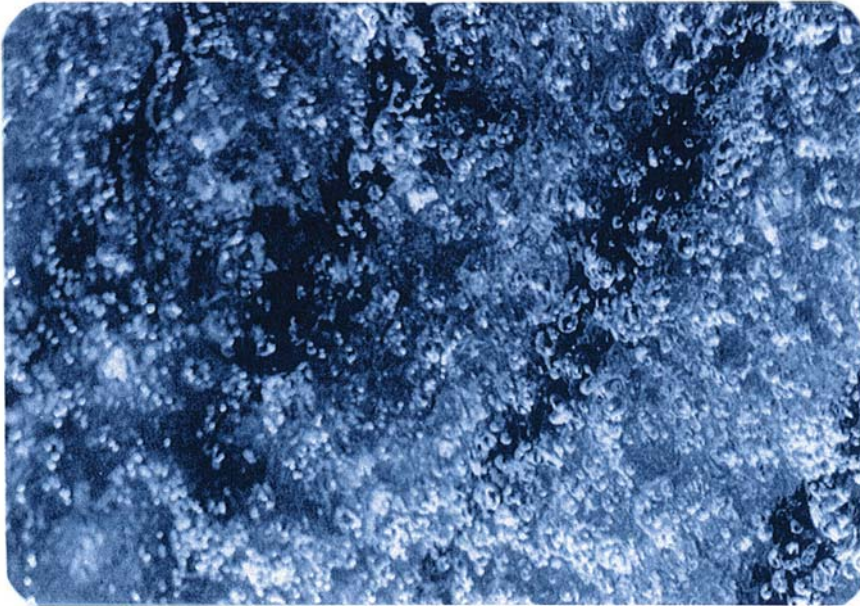

The view above shows a CJ Ice Builder complete with gravity feed ammonia system. This outside installation is located at Cloverland Green Spring Dairy in Baltimore, MD.

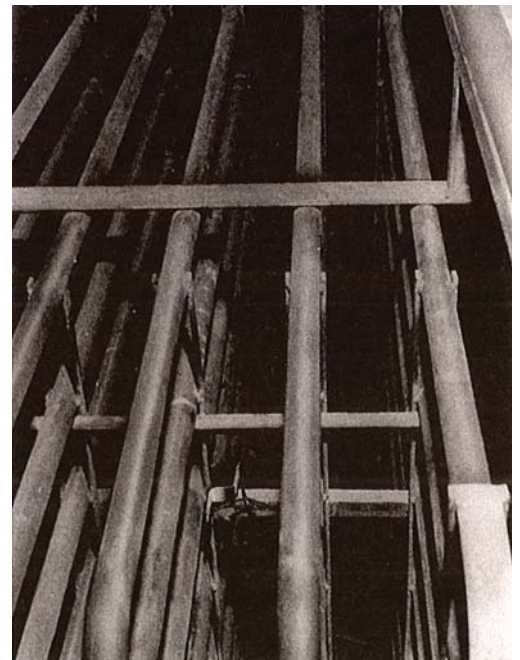

Illustration, above, looks down into a relatively large CJ Air Agitated Ice Builder, showing upper sections of coils and the rugged supporting members.

# Instant Chilled Water



CJ's Open-Type Chilled Water Unit with easily removed covers is of sanitary design and may be used to chill liquid product (32°-33°) directly or to chill ingredient or circulating water. It is, in effect, an all-purpose unit. Ask for catalog section H.



CJ offers a complete line of plate heat exchange equipment especially engineered for various processing of potable and other liquids including regeneration, heating and cooling. All stainless steel is utilized in contact with liquids, resulting in long life and high efficiencies. Ask for catalog section K.



**Chester-Jensen Co., Inc.**

P.O. Box 908  
Chester, PA 19016-0908  
(800) 685-3750  
Tel: (610) 876-6276  
Fax: (610) 876-0485

Branch Factory  
125 South Main Street  
Cattaraugus, NY 14719  
Tel: (716) 257-3421  
Fax: (716) 257-3764

[www.chester-jensen.com](http://www.chester-jensen.com)  
email: [htxchnng@chester-jensen.com](mailto:htxchnng@chester-jensen.com)